

# Network Camera

## Installation Manual

Before operating the unit, please read this manual thoroughly and retain it for future reference.

## PELA ExwavePRO

## SNC-DM110 SNC-DS10

<http://www.sony.net/>

© 2008 Sony Corporation Printed in China

## Owner's Record

The model and serial numbers are located on the bottom. Record these numbers in the spaces provided below. Refer to these numbers whenever you call upon your Sony dealer regarding this product.

Model No. \_\_\_\_\_ Serial No. \_\_\_\_\_

## WARNING

**To reduce a risk of fire or electric shock, do not expose this product to rain or moisture.**

**To avoid electrical shock, do not open the cabinet. Refer servicing to qualified personnel only.**

### WARNING

This installation should be made by a qualified service person and should conform to all local codes.

### WARNING

A readily accessible disconnect device shall be incorporated in the building installation wiring.

### WARNING (for Installers only)

Instructions for installing the equipment on the ceiling or the wall: After the installation, ensure the connection is capable of supporting at least a force of 50 Newtons (N) downwards.

### CAUTION

The rating label is located on the bottom.

### CAUTION for LAN port

For safety reason, do not connect the LAN port to any network devices that might have excessive voltage.

The LAN port of this unit is to be connected only to the devices whose power feeding meets the requirements for SELV (Safety Extra Low Voltage) and complies with Limited Power Source according to IEC 60950-1.

### Power Supply

#### Caution for U.S.A. and Canada

The SNC-DM110/DS10 operates on 24V AC or 12V DC. The SNC-DM110/DS10 automatically detects the power.

Use a Class 2 power supply which is UL Listed (in the U.S.A.) or CSA-certified (in Canada).

#### Caution for other countries

The SNC-DM110/DS10 operates on 24V AC or 12V DC. The SNC-DM110/DS10 automatically detects the power. Use a power supply rated 24 V AC or 12 V DC which meets the requirements for SELV (Safety Extra Low Voltage) and complies with Limited Power Source according to IEC 60950-1.

#### For customers in the U.S.A.

This device complies with Part 15 of the FCC Rules. Operation is subject to the following two conditions: (1) This device may not cause harmful interference, and (2) this device must accept any interference received, including interference that may cause undesired operation.

NOTE: This equipment has been tested and found to comply with the limits for a Class A digital device, pursuant to part 15 of the FCC Rules. These limits are designed to provide reasonable protection against harmful interference when the equipment is operated in a commercial environment. This equipment generates, uses, and can radiate radio frequency energy and, if not installed and used in accordance with the instruction manual, may cause harmful interference to radio communications. Operation of this equipment in a residential area is likely to cause harmful interference in which case the user will be required to correct the interference at his own expense.

You are cautioned that any changes or modifications not expressly approved in this manual could void your authority to operate this equipment.

All interface cables used to connect peripherals must be shielded in order to comply with the limits for a digital device pursuant to Subpart B or Part 15 of FCC Rules.

#### For customers in Canada

This Class A digital apparatus complies with Canadian ICES-003.

Cet appareil numérique de la classe A est conforme à la norme NMB-003 du Canada.

#### For the customers in Europe

The manufacturer of this product is Sony Corporation, 1-7-1 Konan, Minato-ku, Tokyo, Japan.

The Authorized Representative for EMC and product safety is Sony Deutschland GmbH, Hedelfinger Strasse 61, 70327 Stuttgart, Germany. For any service or guarantee matters please refer to the addresses given in separate service or guarantee documents.

#### For the customers in Europe, Australia and New Zealand

### WARNING

This is a Class A product. In a domestic environment, this product may cause radio interference in which case the user may be required to take adequate measures.

In the case that interference should occur, consult your nearest authorized Sony service facility.

This apparatus shall not be used in the residential area.

### ATTENTION

The electromagnetic fields at specific frequencies may influence the picture of the unit.

#### For the customers in Taiwan only



廢電池請回收

## Notes on Use

### Data and security

- You should keep in mind that the images or audio you are monitoring may be protected by privacy and other legal rights, and the responsibility for making sure you are complying with applicable laws is yours alone.
- Access to the images and audio is protected only by a user name and the password you set up. No further authentication is provided nor should you presume that any other protective filtering is done by the service. Since the service is Internet-based, there is a risk that the image or audio you are monitoring can be viewed or used by a third-party via the network.
- SONY IS NOT RESPONSIBLE, AND ASSUMES ABSOLUTELY NO LIABILITY TO YOU OR ANYONE ELSE, FOR SERVICE INTERRUPTIONS OR DISCONTINUATIONS OR EVEN SERVICE CANCELLATION. THE SERVICE IS PROVIDED AS-IS, AND SONY DISCLAIMS AND EXCLUDES ALL WARRANTIES, EXPRESS OR IMPLIED, WITH RESPECT TO THE SERVICE INCLUDING, BUT NOT LIMITED TO, ANY OR ALL IMPLIED WARRANTIES OF MERCHANTABILITY, FITNESS FOR A PARTICULAR PURPOSE, OR THAT IT WILL OPERATE ERROR-FREE OR CONTINUOUSLY.
- Always verify that the unit is operating properly before use. SONY WILL NOT BE LIABLE FOR DAMAGES OF ANY KIND INCLUDING, BUT NOT LIMITED TO, COMPENSATION OR REIMBURSEMENT ON ACCOUNT OF THE LOSS OF PRESENT OR PROSPECTIVE PROFITS DUE TO FAILURE OF THIS UNIT, EITHER DURING THE WARRANTY PERIOD OR AFTER EXPIRATION OF THE WARRANTY, OR FOR ANY OTHER REASON WHATSOEVER.
- If you lose data by using this unit, SONY accepts no responsibility for restoration of the data.

### Operating or storage location

Do not shoot an extremely bright object (an illumination, the sun, etc.). Also, avoid operating or storing the camera in the following locations, as these can be a cause of a malfunction.

- Extremely hot or cold places (Operating temperature: 0 °C to +50 °C [32 °F to 122 °F])
- Exposed to direct sunlight for a long time, or close to heating equipment (e.g., near heaters)
- Close to sources of strong magnetism
- Close to sources of powerful electromagnetic radiation, such as radios or TV transmitters
- Locations subject to strong vibration or shock
- Humid or dusty locations
- Locations exposed to rain
- Locations under the influence of fluorescent light or reflection of a window
- Under an unsteady light (the image will flicker.)

### Ventilation

To prevent heat buildup, do not block air circulation around the camera.

### Transportation

When transporting the camera, repack it as originally packed at the factory or in materials of equal quality.

### Cleaning

- Use a blower to remove dust from the lens.
- Use a soft, dry cloth to clean the external surfaces of the camera. Stubborn stains can be removed using a soft cloth dampened with a small quantity of detergent solution, then wipe dry.
- Do not use volatile solvents such as alcohol, benzene or thinners as they may damage the surface finishes.

### Note on laser beams

Laser beams may damage a CCD. You are cautioned that the surface of a CCD should not be exposed to laser beam radiation in an environment where a laser beam device is used.

### Regular parts replacement

Some of the parts that make up this product (electrolytic condenser, for example) need replacing regularly depending on their life expectancies.

The lives of parts differ according to the environment or condition in which this product is used and the length of time it is used, so we recommend regular checks.

Consult the dealer from whom you bought it for details.

## Phenomena Specific to CCD Image Sensors

The following phenomena that may appear in images are specific to CCD (Charge Coupled Device) image sensors. They do not indicate malfunctions.

### White flecks

Although the CCD image sensors are produced with high-precision technologies, fine white flecks may be generated on the screen in rare cases, caused by cosmic rays, etc.

This is related to the principle of CCD image sensors and is not a malfunction. The white flecks especially tend to be seen in the following cases:

- when operating at a high environmental temperature
- when you have raised the gain (sensitivity)
- when using the slow shutter

### Vertical smear

When an extremely bright object, such as a strong spotlight or flashlight, is being shot, vertical tails may be produced on the screen, or the image may be distorted.

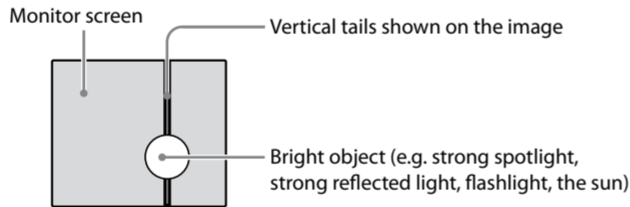

### Aliasing

When fine patterns, stripes, or lines are shot, they may appear jagged or flicker.

## About the Supplied Manuals

### Installation Manual (this document)

This Installation Manual describes the names and functions of parts and controls of the Network Camera, gives connection examples and explains how to set up the camera. Be sure to read the Installation Manual before operating.

### Easy Setup Guide for the Sony Network Camera (stored in the CD-ROM)

The Easy Setup Guide shows you how to set up the camera in order to view the image shot by the camera on a computer.

After installing and connecting the camera following the Installation Manual, perform setup using the Easy Setup Guide.

### User's Guide (stored in the CD-ROM)

The User's Guide describes how to set up the camera and how to control the camera via a Web browser. Operate the camera referring to the User's Guide.

### Using the CD-ROM Manuals

The supplied CD-ROM disc includes the User's Guides and Easy Setup Guides for this unit in PDF format.

### Preparations

The Adobe Reader Version 6.0 or higher must be installed on your computer in order to use the guides stored in the CD-ROM disc.

### Note

If Adobe Reader is not installed, it may be downloaded from the following URL: <http://www.adobe.com/>

### Reading the manual in the CD-ROM

#### 1 Insert the CD-ROM in your CD-ROM drive.

A cover page appears automatically in your Web browser. If it does not appear automatically in the Web browser, double-click on the index.htm file on the CD-ROM.

#### 2 Select and click on the manual that you want to read.

This opens the PDF file of the manual. Clicking an item in the Table of Contents allows you jump to the relevant page.

### Notes

- The files may not be displayed properly, depending on the version of Adobe Reader. In this case, install the latest version, which you can download from the URL mentioned in "Preparations" above.
- If you have lost or damaged the CD-ROM, you can purchase replacement. Contact your Sony service representative.

Adobe and Acrobat Reader are trademarks of Adobe Systems Incorporated in the United States and/or other countries.

## Location and Function of Part

The figure shows the camera without the dome casing and the slit cover.

### Side

Cables ❶, ❷ and ❸ are not connected when the unit comes from the factory.

#### ❶ Audio cable (supplied)

The connector with the longer cable (SP) is used for the line output connector, and the shorter cable (MIC) is used for the microphone/line input connector.

#### ❷ I/O (Input/Output) cable (supplied)

This cable is provided with a sensor input and two alarm outputs.

The wires of the cable control the following signals.

Color of wire	Name
Red	Sensor In +
White	Sensor In - (GND)
Black	Alarm Out 1 +
Yellow	Alarm Out 1 -
Brown	Alarm Out 2 +
Green	Alarm Out 2 -

For details on each function and required settings, see the User's Guide stored in the supplied CD-ROM.

For the wiring, see "Connecting the I/O cable."

#### ❸ Indoor wiring slit (knockout type)

When you wire indoors, cut this part with pliers or similar and feed the cables through it.

### Caution

Take care not to trap the cables between the camera and the ceiling or the wall. If the cable is trapped, it may cause a fire or electric shock due to breaking.

#### ❹ Camera head holder

#### ❺ Lens

❹ LAN cable (RJ-45) (supplied and connected to the camera at the factory)  
Connect this cable to a hub or computer on the 10BASE-T or 100BASE-TX network using a network cable (UTP, category 5).

#### ❻ Power input cable (supplied and connected to the camera at the factory)

Connect this cable to a 24V AC or 12V DC power supply system. You can screw an extension cable in the connector tip attached at the end of the cable.

#### ❼ BNC cable (supplied)

Outputs a composite video signal.

#### ❽ Lens ring fixing screw

Loosen this screw before adjusting the zoom and focus, and tighten it to fix the lens position. The screw can be inserted at one of three points.

#### ❾ Zoom ring

Turn this ring to adjust the angle of view.

#### ❿ Focus ring

Turn this ring to adjust the focus.

## Inside

### ❶ Camera unit

### ❷ LAN port

Connect the supplied LAN cable.

### ❸ AC / DC IN (power input) connector

Connect the supplied power input cable to this connector.

### ❹ EXT CTRL (external control input/output) connector

Connect the supplied I/O cable to this connector.

### ❺ POWER indicator (green)

When the power is supplied to the camera, the camera starts checking the system. If the system is normal, this indicator lights up.

### ❻ NETWORK indicator (green)

The indicator flashes in green when the camera is connected to the network. The indicator goes off when the camera is not connected to the network.

### ❼ VIDEO OUT (video output) indicator

The indicator shows the camera operation mode according to the VIDEO OUT selector setting. It goes off in IP mode, lights in green in NTSC+IP mode and lights in orange in PAL+IP mode.

### ❽ Camera installation hole (2 positions)

Make sure to tighten the screws securely when installing the camera.

### ❾ MONITOR output jack

Connect this jack to a video input connector of a video monitor. You can adjust the camera or lens while looking at the image on the video monitor. After adjusting the camera or lens, disconnect the cable.

### ❿ VIDEO OUT (video output) connector

Connect the supplied BNC cable to this connector.

### ⓫ AUDIO connector

Connect the supplied audio cable to this connector.

### ⓬ AUDIO IN (audio input) selector

Select the level of the audio signal to be input to the microphone/line input connector.

**LINE:** line input level

**MIC:** microphone input level

The factory default setting is MIC.

### ⓭ IRIS selector

Use this selector when adjusting the focus of the lens.

Each time you press the selector button, the iris of the lens switches between open and normal. (The factory default setting is normal.)

When the iris is set to open, the IRIS OPEN indicator and the focus assist indicator appear on a monitor screen. When the VIDEO OUT selector is set to the NTSC+IP or PAL+IP mode, the indicators are displayed on the monitor connected to the MONITOR jack or VIDEO OUT connector. When it is set to the IP mode, the indicators are displayed on the monitor of the computer.

For details, see "Focus Assist Function" on the reverse side.

### ⓮ VIDEO OUT selector

Each time you press the selector button, the camera operation mode switches from IP mode to NTSC+IP mode to PAL+IP mode cyclically, and the VIDEO OUT indicator shows the selected mode. (The factory default setting is IP mode.)

When adjusting the field of view using a video monitor, select the appropriate video signal with this selector.

**IP mode:** The video signal is not output from the MONITOR jack or VIDEO OUT connector. (VIDEO OUT indicator: off)

**NTSC+IP mode:** The NTSC video signal is output from the MONITOR jack and VIDEO OUT connector. (VIDEO OUT indicator: lights in green)

**PAL+IP mode:** The PAL video signal is output from the MONITOR jack and VIDEO OUT connector. (VIDEO OUT indicator: lights in orange)

### Note

In NTSC+IP or PAL+IP mode, the video and audio signals can be output to a computer via a LAN although there are certain restrictions. For details of the restrictions, see the User's Guide.

### ⓯ Reset switch

To reset the camera to the factory default settings, hold down this switch with a point and supply the power to the camera.

### ⓰ Camera head fixing screw

First loosen the screw and face the camera head to the desired direction, then tighten the screw to fix it.

(continued on the reverse side)

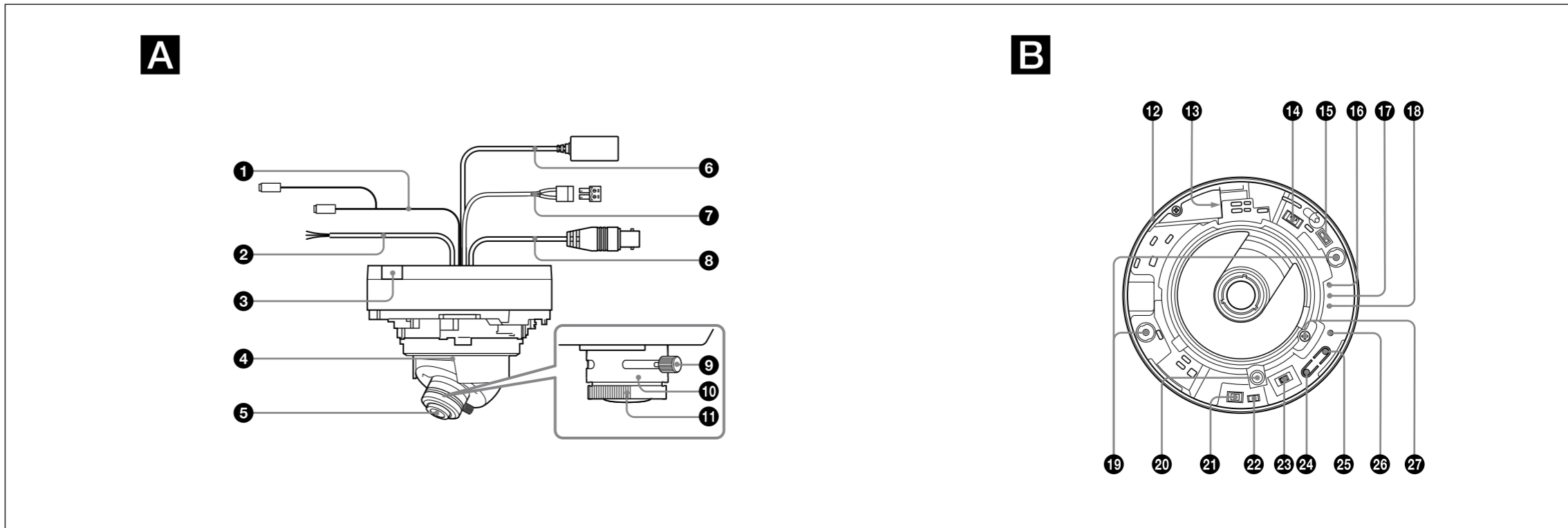

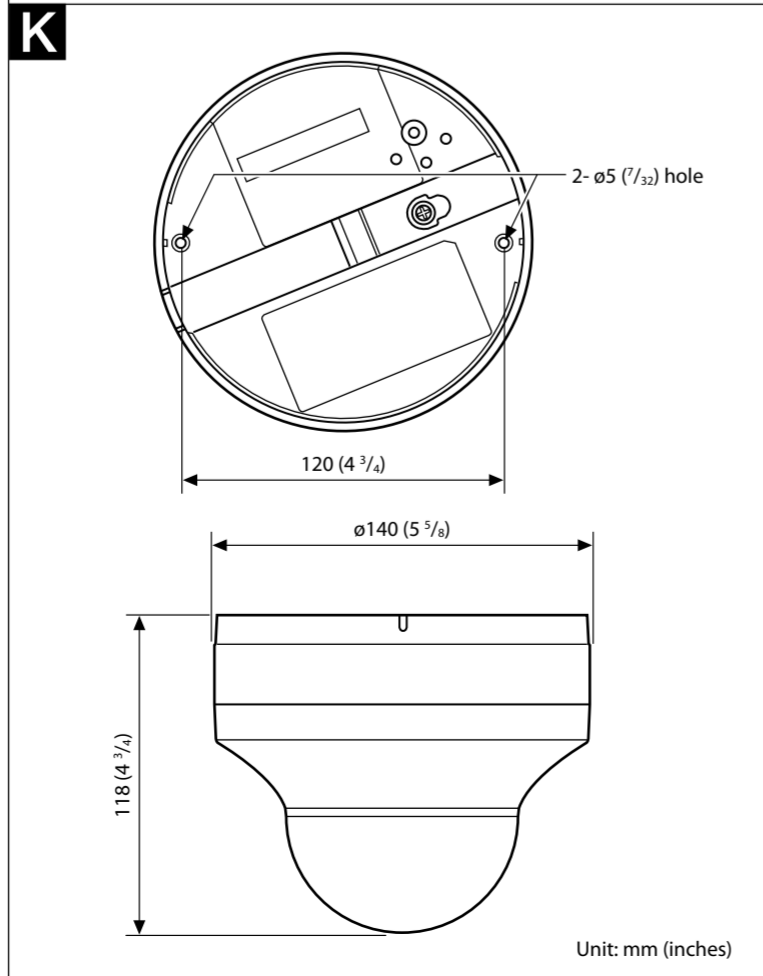
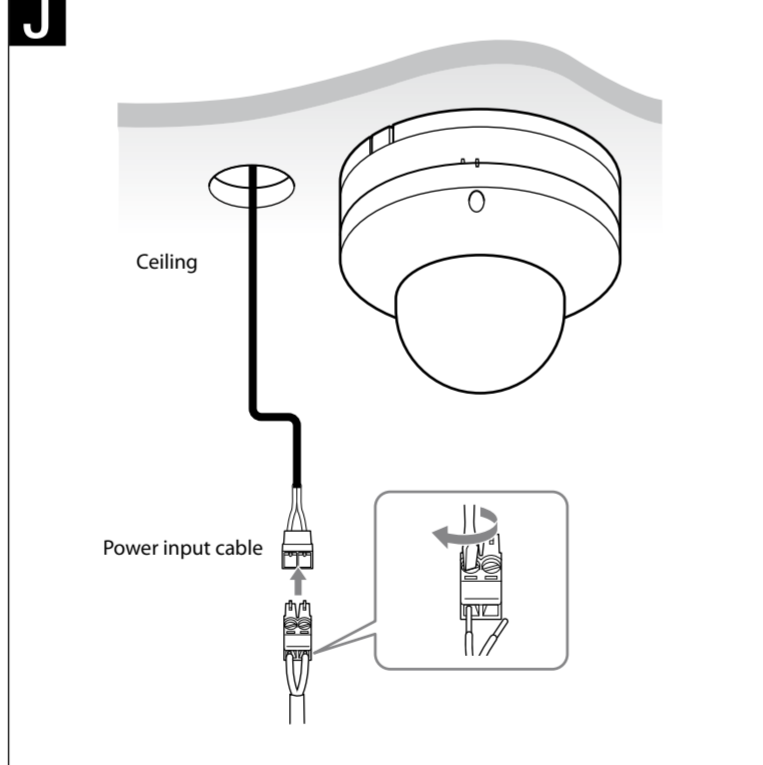
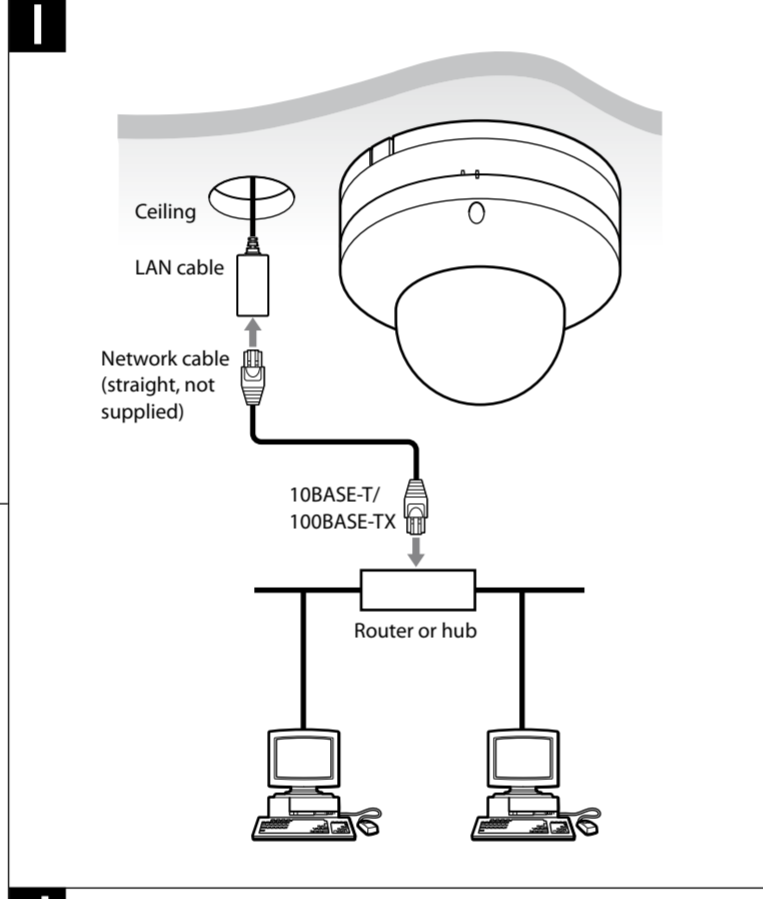
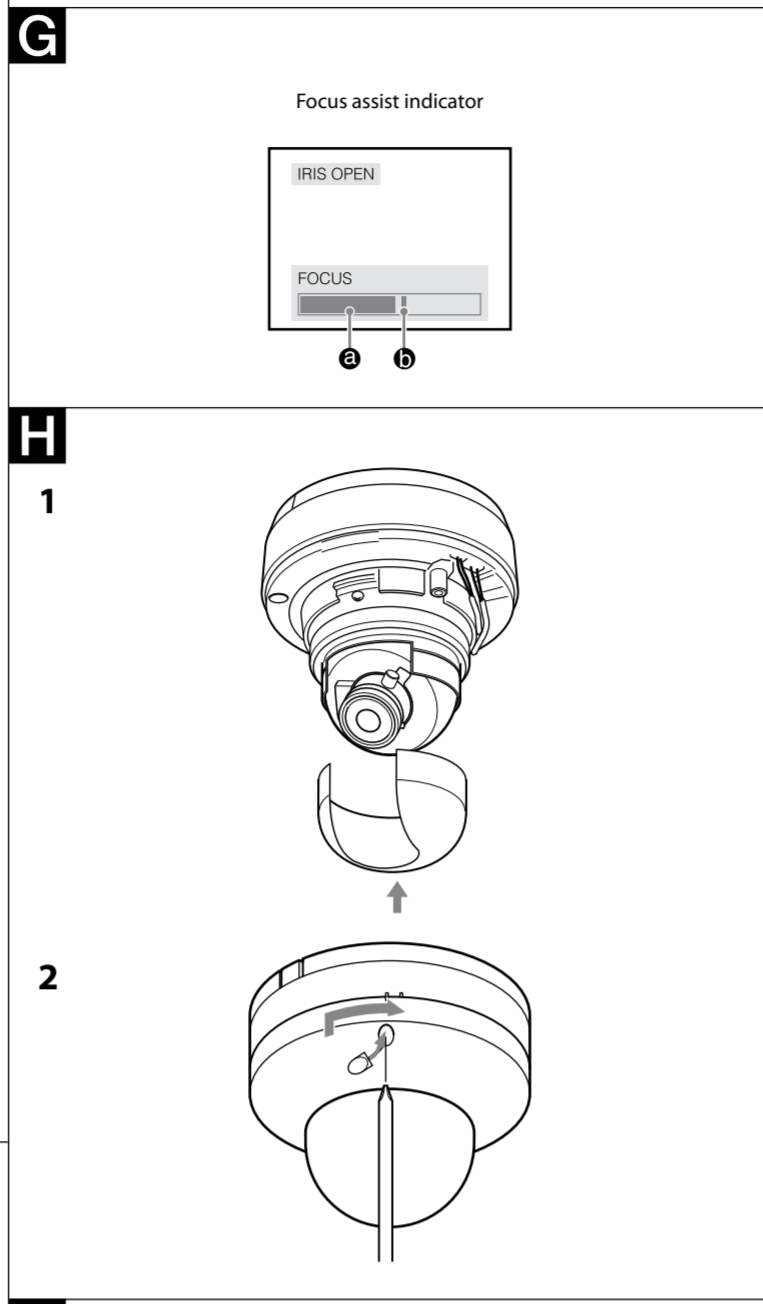
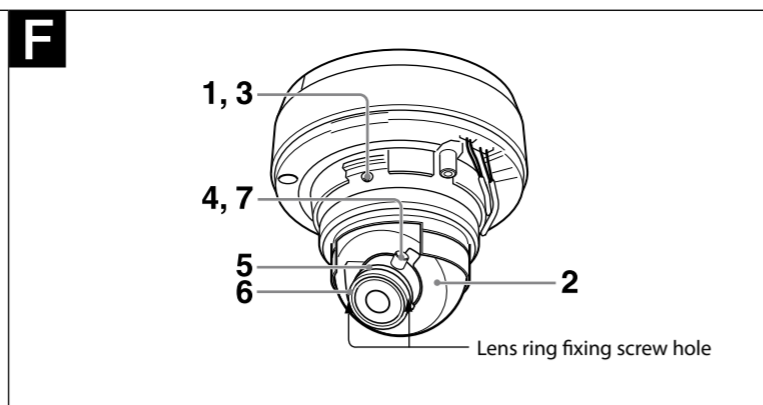
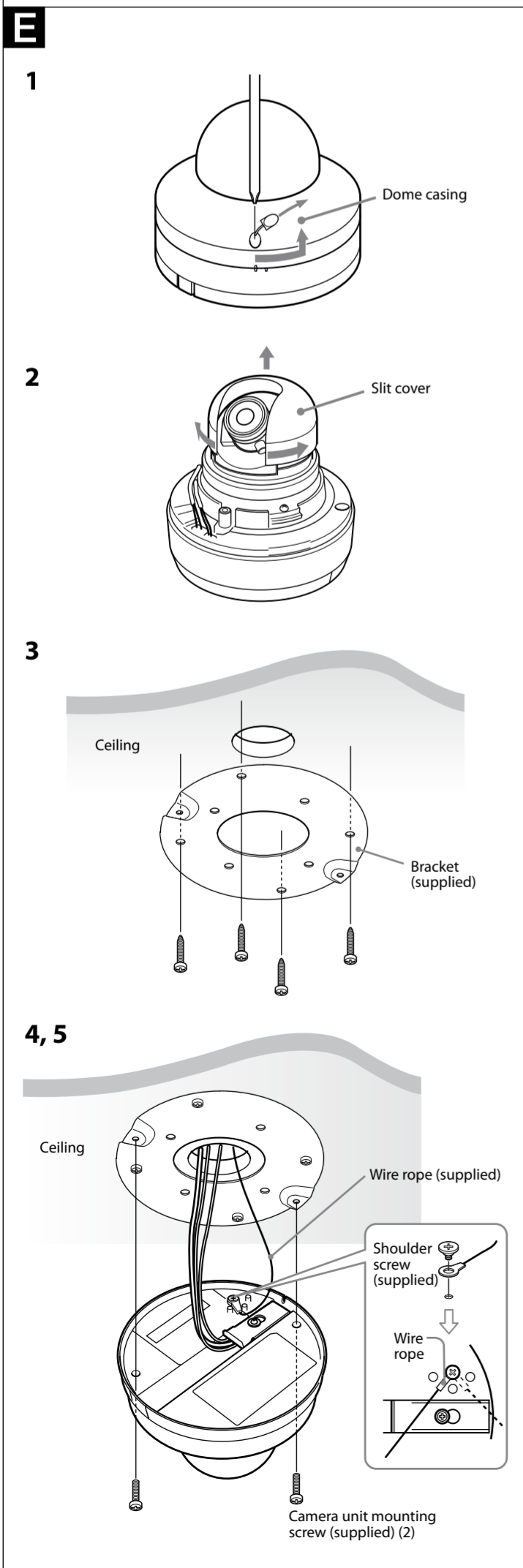
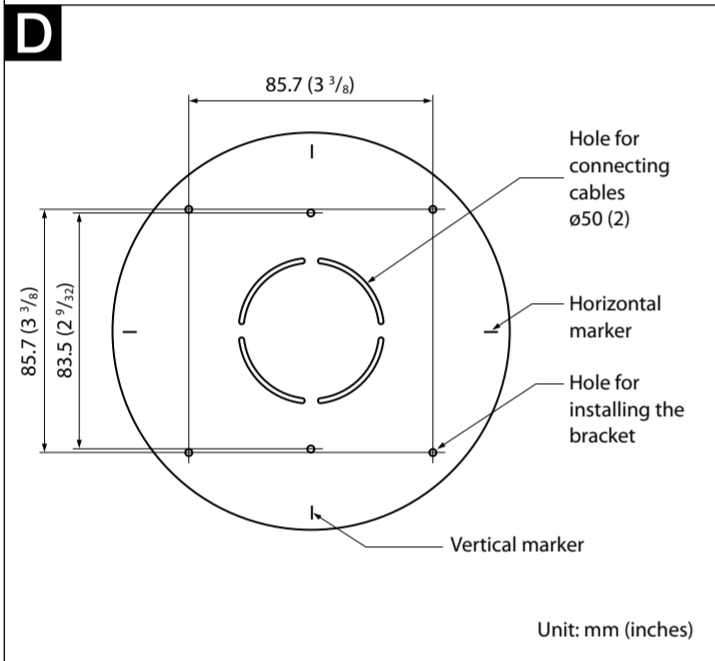
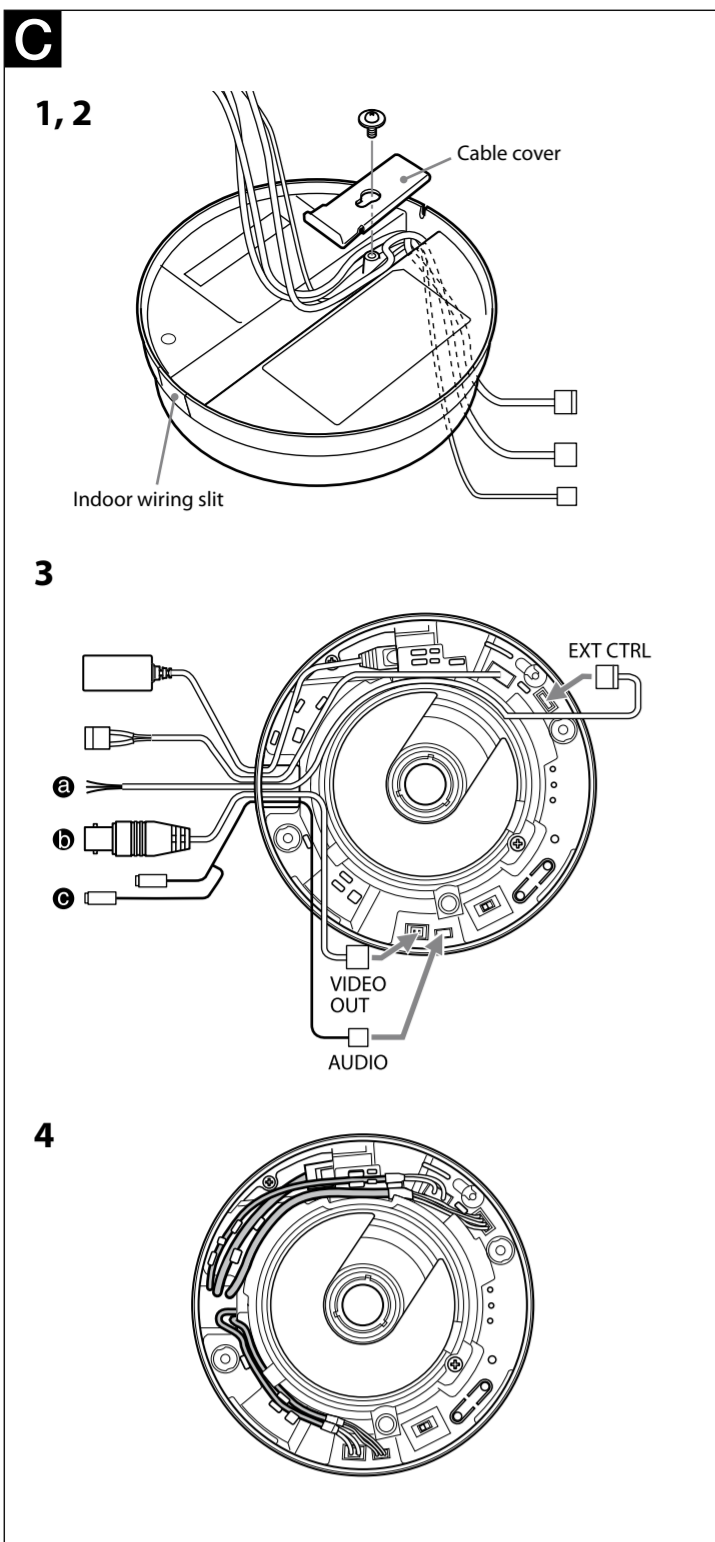

**Preparations**

**Connecting the Cables to the Camera** **C**

Before installation, connect the supplied cables to the camera as required for your usage and wire them.

- Remove the screw on the bottom of the camera unit to detach the cable cover.
- Pass the cables through the hole on the bottom of the camera unit.
- Connect the cables to the connectors on the camera unit.
  - I/O cable: to EXT CTRL connector
  - BNC cable: to VIDEO OUT connector
  - Audio cable: to AUDIO connector
- Wire the cables along the cable guides on the camera unit. Position the cables under the cable clamps.

**Note**

To prevent the cables from being trapped by the dome casing, be sure to wire them using the cable guides and clamps.

- Pull the cables gently from the bottom of the camera unit to take in the slack, and fix the cable cover with the screw.

To install the camera on a wall, cut the indoor wiring slit and pass the cables through it.

**Installation**

**WARNING**

- If you attach the camera in the height such as the wall or the ceiling, etc., entrust the installation to an experienced contractor or installer.
- If you install the camera on the ceiling, ensure that the ceiling is strong enough to withstand the weight of the camera plus the bracket and then install the camera securely. If the ceiling is not strong enough, the camera may fall and cause serious injury.
- To prevent the camera from falling, make sure to attach the supplied wire rope.
- If you attach the camera to the ceiling, check periodically, at least once a year, to ensure that the connection has not loosened. If conditions warrant, make this periodic check more frequently.

**Deciding the Installation Location of the Camera** **D**

After deciding the direction in which the camera will shoot, make the required hole (ø 50 mm (2 inches)) for the connecting cables using the supplied template. Then decide the two or four mounting hole positions to install the bracket.

**Mounting screws**

The supplied bracket is provided with ø 4.5 mm (7/16 inch) mounting holes. Install the bracket on a ceiling or wall with screws through two or four mounting holes: two 83.5 mm (3 3/16 inch)-pitched holes or four 85.7 mm (3 3/8 inch)-pitched holes. The required mounting screws differ depending on the installation location and its material. (Mounting screws are not supplied.)

**Steel wall or ceiling:** Use M4 bolts and nuts.

**Wooden wall or ceiling:** Use M4 tapping screws. The panel thickness must be 15 mm (5/8 inch) or more.

**Concrete wall:** Use anchors, bolts and plugs suitable for concrete walls.

**Junction box:** Use screws to match the holes on the junction box.

**WARNING**

The required mounting screws differ depending on the installation location and its material. If you do not secure the camera with the appropriate mounting screws, the camera may fall off.

**Installing the Camera** **E**

- Remove the dome casing.
  - Pull out the screw cover and loosen the screw with a Phillips screwdriver.
  - Turn the dome casing to the curved mark position on the camera unit, and remove the dome casing from the camera unit. When the screw catches on the screw hole, pull up the screw.
- Remove the slit cover. Remove the slit cover expanding it.
- Install the supplied bracket on the ceiling or wall. Refer to "Mounting screws" for screws to be used.
- Fix the supplied wire rope to the camera unit and the ceiling or wall.
  - Fix the wire rope with the supplied shoulder screw to the hole for the wire rope on the bottom of the camera unit. Pass the wire rope between the wire rope guides.
  - Fix the wire rope to the ceiling or wall.
- Attach the camera unit to the bracket with the supplied two screws. The screws have a fall-prevention mechanism. The screws inserted into the screw holes of the camera unit do not fall even if you turn the camera unit upside down.

**Note**

If you cannot use screws on a ceiling or wall, or if you want to make the camera less conspicuous, use the YT-ICB45 in-ceiling bracket (optional) with which you can mount the camera on the ceiling.

**Adjusting the Camera Direction and Coverage** **F**

- Loosen the camera head fixing screw.
- Adjust the camera to turn the lens in the desired direction.
- Tighten the camera head fixing screw to fix the camera.
- Loosen the lens ring fixing screw.
- Turn the zoom ring to adjust the angle of view.
- Turn the focus ring to adjust the focus.
- Tighten the lens ring fixing screw to fix the zoom and the focus.
- Repeat steps 1 to 7 until the coverage and the focus are determined.

**Notes**

- When you adjust the camera head angle without loosening camera head fixing screw, an internal part may be damaged.
- If the camera head is too heavy to be adjusted, loosen the camera head fixing screw until it moves freely.
- When the lens is not put in the slit of the camera head holder, the moving range of the camera head is limited.
- Do not turn the lens more than 360 degrees, as this may damage the wiring inside.
- There are three screw holes for fixing the lens ring at 120 degree intervals. If the lens ring fixing screw poses a problem for adjusting the camera direction and coverage due to the direction of the camera head, detach the screw and reattach it to another screw hole, then adjust the camera direction and coverage again.
- When adjusting the angle, be sure that the TOP mark on the camera head section faces the ceiling. If the camera is installed with the TOP mark facing the floor, the image appears upside down.

**Focus Assist Function** **G**

- Select the camera operation mode to match the video monitor in use with the VIDEO OUT selector.
- Set the iris to open with the IRIS selector. The IRIS OPEN indicator and the focus assist indicator appear on the monitor screen. The length of bar **a** varies according to the degree of focus adjustment. Bar **b** indicates the peak hold value.
- Turn the focus ring until bar **a** reaches the peak hold value **b**.

**Attaching the Dome Casing** **H**

- Attach the slit cover.
 

**Notes**

  - The proper position of the slit cover is slightly apart from the camera mount. Do not push in by force.
  - If you cannot attach the slit cover because the barrier of the lens ring fixing screw prevents it, attach the lens ring fixing screw to another screw hole. There are three screw holes for the lens ring fixing screw on the concentric circle.
- Fix the dome casing and the camera unit.
  - Align the carved mark on the dome casing with that on the camera unit, and turn the dome casing in the direction of the arrow.
  - Secure the screw and put the screw cover.

**Connection**

**Connecting to the Network** **I**

Connect the LAN cable of the camera to a router or hub in the network using the network cable (straight, not supplied).

**To connect to a computer**

Connect the LAN cable of the camera to the network connector of a computer using the network cable (cross, not supplied).

**Connecting the Power Source**

There are three ways to supply the power source to this camera, as follows.

- 12 V DC
- 24 V AC
- Power supply equipment pursuant to IEEE802.3af (PoE\* system)

\*PoE means Power over Ethernet.

**Note**

If the power is supplied from the power input cable and LAN cable at the same time, the power from the LAN cable has priority over the other.

**Connecting to 12 V DC or 24 V AC source** **J**

Connect the power input cable of the camera to a 12 V DC or 24 V AC source.

- Use a 12 V DC or 24 V AC source isolated from 100 to 240 V AC. Each usable voltage ranges are as follows.
  - 12 V DC: 10.8 V to 13.2 V
  - 24 V AC: 21.6 V to 26.4 V
- Use UL cable (VW-1 style 1007) for these connections.

**Connecting to the power supply equipment pursuant to IEEE802.3af**

The power supply equipment pursuant to IEEE802.3af supplies the power through the LAN cable. For details, refer to the Instruction Manual of the equipment.

**Connecting the I/O Cable**

Connect the wires of the I/O cable as follows:

**Wiring diagram for sensor input**

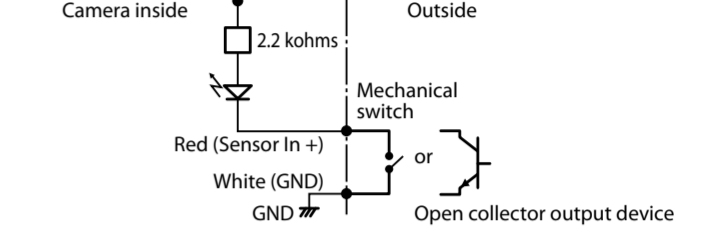

**Wiring diagram for alarm output**

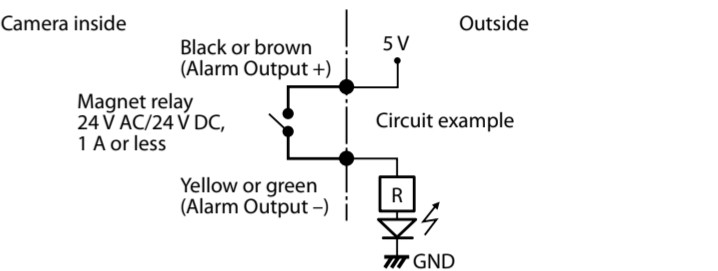

**Specifications**

**Compression**

Video compression format	JPEG/MPEG4
Audio compression format	G.711/G.726 (40, 32, 24, 16 kbps)
Maximum frame rate	30 fps

**Camera SNC-DM110**

Signal system	NTSC color system/PAL color system (switchable)
Image device	1/3 type interline transfer (ExwavePRO) CCD
	Total picture elements: Approx. 1,320,000
	Effective picture elements: Approx. 1,250,000
Synchronization	Internal synchronization
Horizontal resolution	600 TV lines (analog video)
Video S/N (AGC 0 dB)	50 dB or more
Minimum illumination (F1.3, 50 IRE)	0.8 lx (AGC 30 dB, normal readout), 0.2 lx (AGC 36 dB, Light funnel ON)

**Camera SNC-DS10**

Signal system	NTSC color system/PAL color system (switchable)
Image device	1/4 type interline transfer (ExwavePRO) CCD
	Total picture elements: Approx. 350,000
	Effective picture elements: Approx. 330,000
Synchronization	Internal synchronization
Horizontal resolution	400 TV lines (analog video)
Video S/N (AGC 0 dB)	50 dB or more
Minimum illumination (AGC 36 dB, F1.3, 50 IRE)	0.3 lx

**Lens (standard equipment of SNC-DM110)**

Focal length	2.8 to 9.5 mm
Maximum relative aperture	F1.3
View angle	Vertical: 73.6° to 21.9°
	Horizontal: 100.3° to 29.1°
	300 mm (11 7/8 inches)

**Lens (standard equipment of SNC-DS10)**

Focal length	2.8 to 10 mm
Maximum relative aperture	F1.3
View angle	Vertical: 54.7° to 15.6°
	Horizontal: 73.9° to 20.8°
	300 mm (11 7/8 inches)

**Interface**

LAN port	10BASE-T/100BASE-TX, auto negotiation (RJ-45)
I/O port	Sensor input: × 1, make contact, break contact
	Alarm output: × 2, 24 V AC/DC, 1 A (mechanical relay outputs electrically isolated from the camera)
Video output	VIDEO OUT: BNC, 1.0 Vp-p, 75 ohms, unbalanced, sync negative
Microphone input*	Minijack (monaural)
	Plug-in-power supported (rated voltage: 2.5 V DC)
Line input*	Minijack (monaural)
	*The microphone input and the line input are switchable with a selector.
Line output	Minijack (monaural), Maximum output level: 1 Vrms

**Others**

Power supply	12 V DC ± 10%
	24 V AC ± 10%, 50/60 Hz
	IEEE802.3af compliant (PoE system)
Power consumption	SNC-DM110: 8 W max.
	SNC-DS10: 7.5 W max.
Operating temperature	0 °C to +50 °C (32 °F to 122 °F)
Storage temperature	-20 °C to +60 °C (-4 °F to +140 °F)
Operating humidity	20 to 80 %
Storage humidity	20 to 95 %
Dimensions (diameter/height)	140 × 118 mm (5 1/2 × 4 3/4 inches), not including the projecting parts
Mass	Approx. 780 g (1 lb 12 oz), not including the cables and bracket
Supplied accessories	CD-ROM (User's Guides, Easy Setup Guides and supplied programs) (1), Bracket (1), Template (1), Wire rope (1), Camera unit mounting screws (2), Shoulder screw M4 (1), Audio cable (1), I/O cable (1), LAN cable (1), BNC cable (1), Power input cable (1), Installation Manual (this document) (1 set), B&P Warranty Booklet (1)

**Optional accessory**

In-ceiling bracket YT-ICB45

Design and specifications are subject to change without notice.